

MW 35/19 - Mounting bracket

5040052

<https://www.phoenixcontact.com/us/products/5040052>

Please be informed that the data shown in this PDF document is generated from our online catalog. Please find the complete data in the user documentation. Our general terms of use for downloads are valid.



Plastic mounting bracket, with NS 35/7.5 DIN rail, to snap onto modular terminal blocks with a universal foot, profile length: 19 mm

Commercial data

Item number	5040052
Packing unit	10 pc
Minimum order quantity	10 pc
Note	Made to order (non-returnable)
Sales key	BE64
Product key	BE64UX
GTIN	4017918167363
Weight per piece (including packing)	8.2 g
Weight per piece (excluding packing)	7.64 g
Customs tariff number	85369010
Country of origin	DE

MW 35/19 - Mounting bracket

5040052

<https://www.phoenixcontact.com/us/products/5040052>

Technical data

Product properties

Product type	Assembly adapter
--------------	------------------

Dimensions

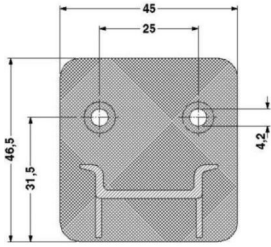
Dimensional drawing	
Width	45 mm
Height	19 mm
Depth	46.5 mm
Length	19 mm

Material specifications

Flammability rating according to UL 94	HB
--	----

Environmental and real-life conditions

Ambient conditions

Ambient temperature (operation)	-60 °C ... 85 °C
Ambient temperature (storage/transport)	-25 °C ... 55 °C (for a short time, not exceeding 24 h, -60 °C to +70 °C)
Ambient temperature (assembly)	-5 °C ... 70 °C
Ambient temperature (actuation)	-5 °C ... 70 °C
Permissible humidity (storage/transport)	30 % ... 70 %

MW 35/19 - Mounting bracket

5040052

<https://www.phoenixcontact.com/us/products/5040052>

Drawings

Dimensional drawing

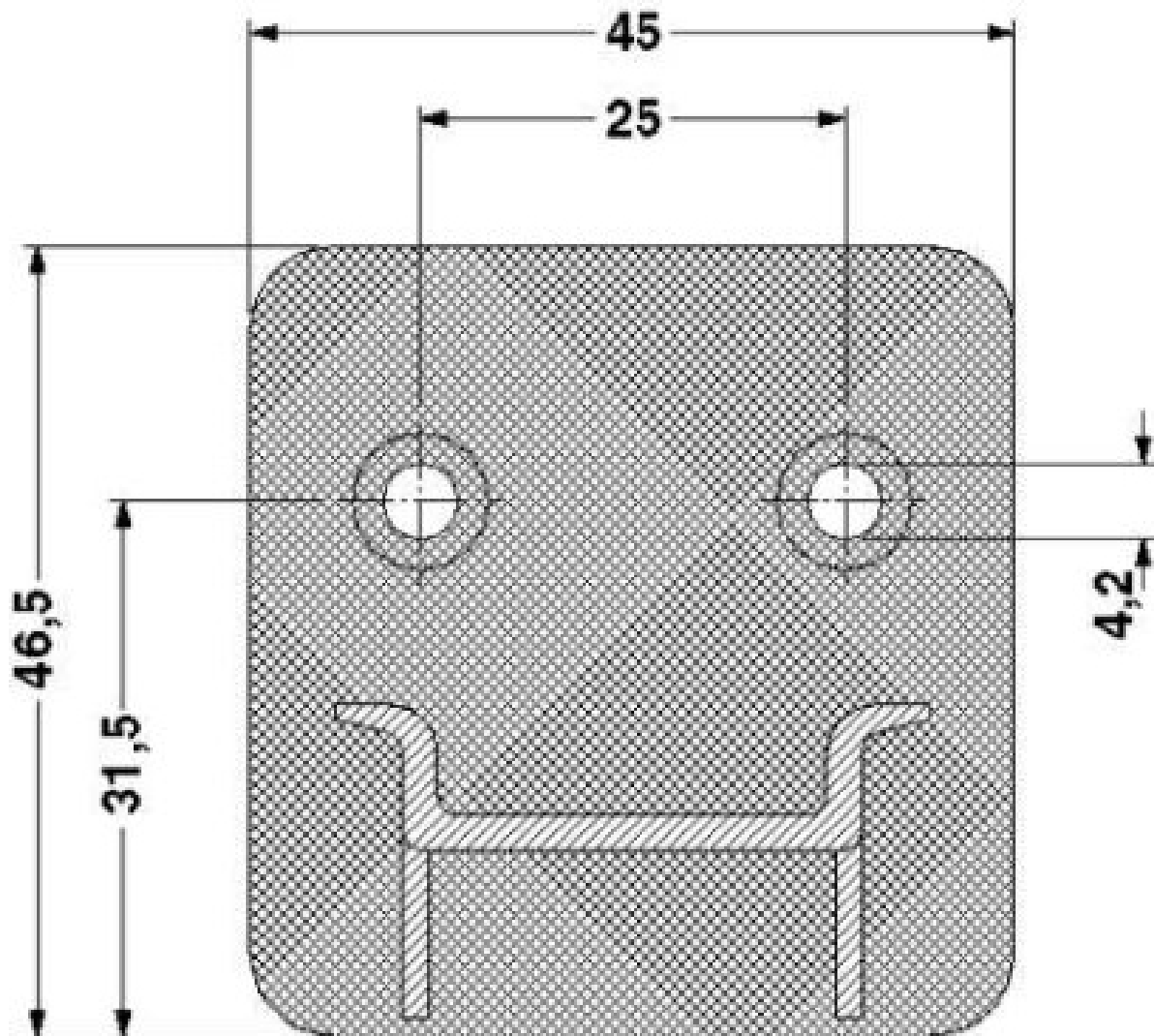

MW 35/19 - Mounting bracket



5040052

<https://www.phoenixcontact.com/us/products/5040052>

Classifications

ECLASS

ECLASS-11.0	27141190
ECLASS-12.0	27141190
ECLASS-13.0	27141190

ETIM

ETIM 9.0	EC002848
----------	----------

UNSPSC

UNSPSC 21.0	39121400
-------------	----------

MW 35/19 - Mounting bracket



5040052

<https://www.phoenixcontact.com/us/products/5040052>

Environmental product compliance

EU RoHS

Fulfills EU RoHS substance requirements	Yes, No exemptions
---	--------------------

China RoHS

Environment friendly use period (EFUP)	EFUP-E
	No hazardous substances above the limits

EU REACH SVHC

REACH candidate substance (CAS No.)	No substance above 0.1 wt%
-------------------------------------	----------------------------

Phoenix Contact 2024 © - all rights reserved
<https://www.phoenixcontact.com>

Phoenix Contact USA
586 Fulling Mill Road
Middletown, PA 17057, United States
(+717) 944-1300
info@phoenixcon.com